

PARÇA KODU PART CODE	PARÇA ADI PART NAME	ERKEK TERMINAL MALE TERMINAL	a ÖLÇÜSÜ (AYAR) a MEASURE (SET)	s ÖLÇÜSÜ (KALINLIK) s MEASURE (THICKNESS)	Malzeme Material	Kaplama / Coating		
						SN	AG	NI
TD 2178.50 RP	STANDART DIŞİ FİŞ M.A.6.3 (0.50) =RP=	0.50	0.35±0.1	0.38±0.05	(CuZn30) Pirinç / Brass	-	-	-
TD 2178.80 DP	STANDART DIŞİ FİŞ M.A.6.3 (0.80) =DP=	0.80	0.55±0.1	0.38±0.05	(CuZn30) Pirinç / Brass	-	-	-
TD 2178.80 RP	STANDART DIŞİ FİŞ M.A.6.3 (0.80) =RP=	0.80	0.55±0.1	0.38±0.05	(CuZn30) Pirinç / Brass	-	-	-
TD 2178.80 RPK	STANDART DIŞİ FİŞ M.A.6.3 (0.80) =RPK=	0.80	0.55±0.1	0.38±0.05	(CuZn30) Pirinç / Brass	+	-	-
TD 2178.80 RÇN	STANDART DIŞİ FİŞ M.A.6.3 PASLANMAZ (0.80) =RÇN=	0.80	0.55±0.1	0.40±0.05	Nikel kaplı çelik / Nickel plated Steel	-	-	+

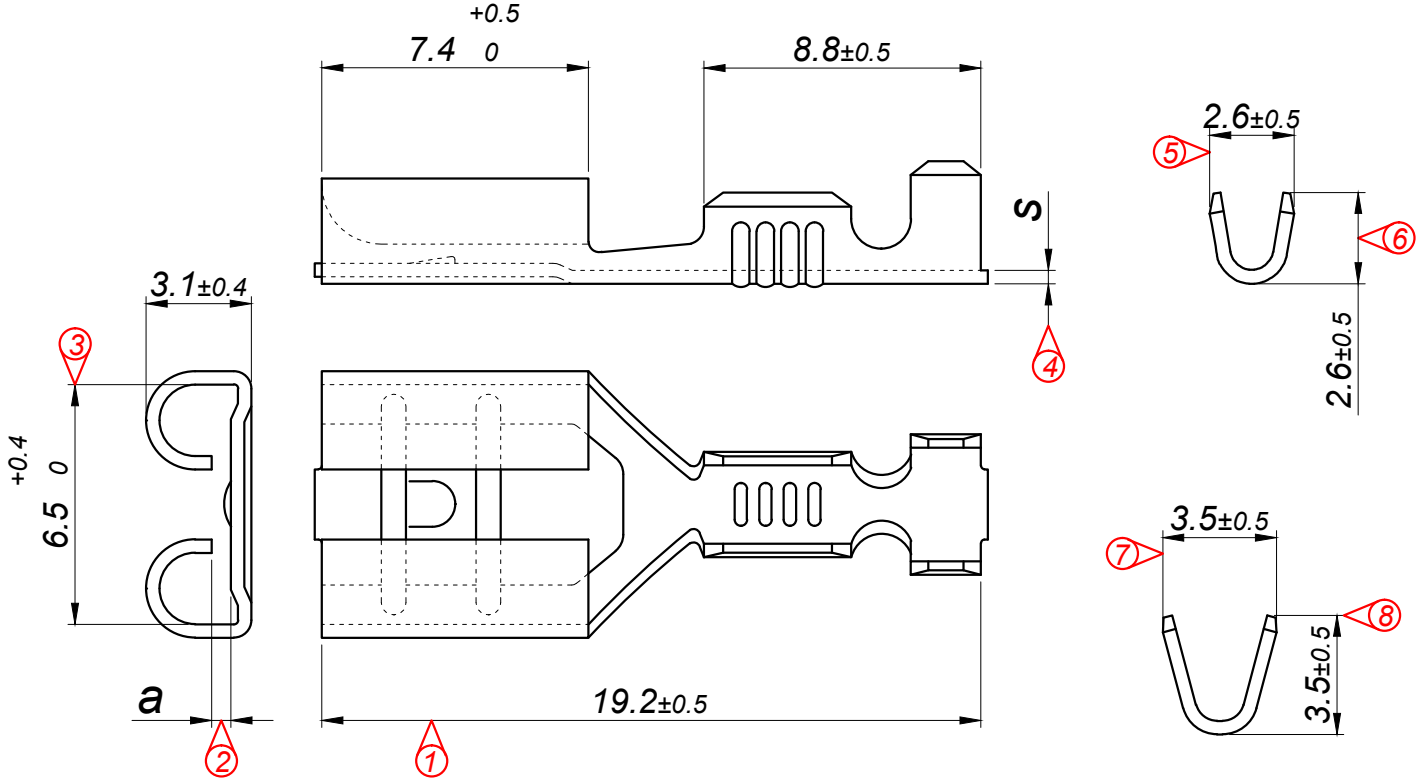

Perspektif
Perspective

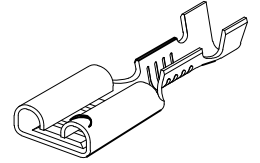

Kalıp çıkış yönü
Mold output direction

Makara açılım yönü
Reel opening direction

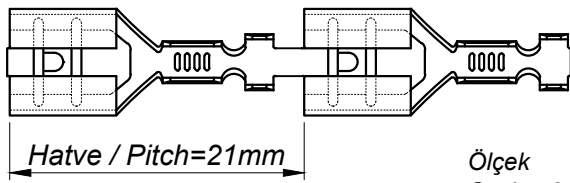

Hatve / Pitch=21mm

Ölçek
Scale : 2 / 1

Kablo Kesiti
Wire Section : 0.35 - 0.50 mm²

Resim üzerinden ölçü almayınız
do not measure on drawing

Tarih / Date	23/03/2017	İmza / Signature	Ölçek / Scale		
Çizen / Desing	T.Topçu		5 / 1		
Onay / Approval	S.Gölcük		No	Değişiklik / Revision	Tarih/Date
	Parça Adı: Part Name	STANDART DIŞİ FİŞ MINİ AYAK 6.3		Parça Kodu: Part Code	TD 2178